

Customer name:

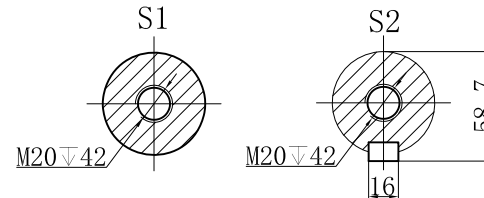
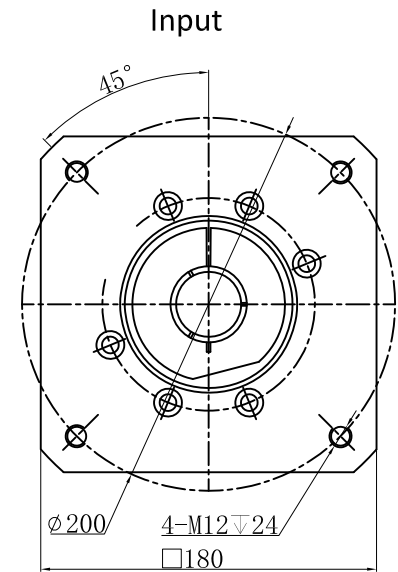
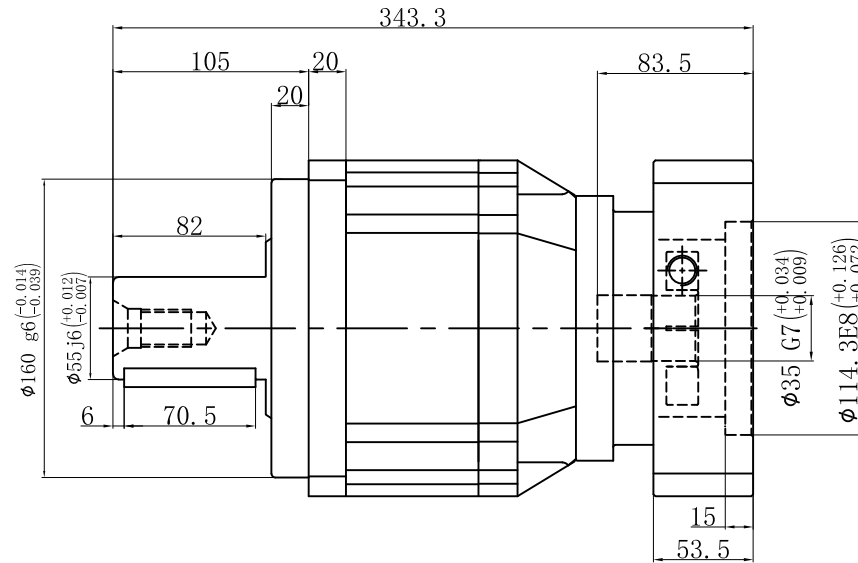
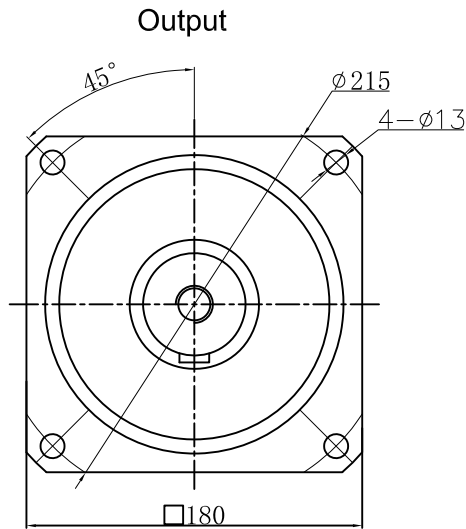

Transmission ratio	(A):1	Mass moments of inertia	(B)Kg.cm ²											
Rated output torque	(C)Nm	Max.output torque	(D)Nm	40	7.42	1000	1800	Sign/Date						
Rated input speed	3000rpm	Max input speed	6000rpm	35	7.42	1100	1980			100	7.03	910	1638	
Max.radial force	14500N	Max.axial force	7250N	30	7.42	1108	1994.4			80	7.03	1000	1800	
Efficiency	≥ 94%	Operating temperature	-20°~+90°	25	7.42	1200	2160			70	7.03	1100	1980	
Mounting position	Any	Lubrication method	Synthetic grease	20	7.42	1050	1890			60	7.03	1108	1994.4	
Weight ±3%	34Kg	Service life	20000h	15	7.42	590	1062		50	7.03	1200	2160		
Standard backlash	≤ 7 arcmin	Protection class	IP65	Ratio	A	B	C	D	Ratio	A	B	C	D	
Motor power		Noise level	66dB	Note										
Motor dimensions				Mark	No.	Sign	Date							

Above specifications are for standard reducer and may be subject to change without notice.