

Customer name:

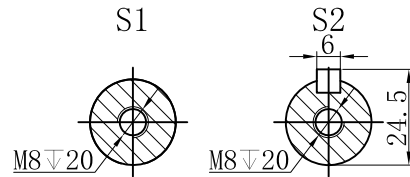
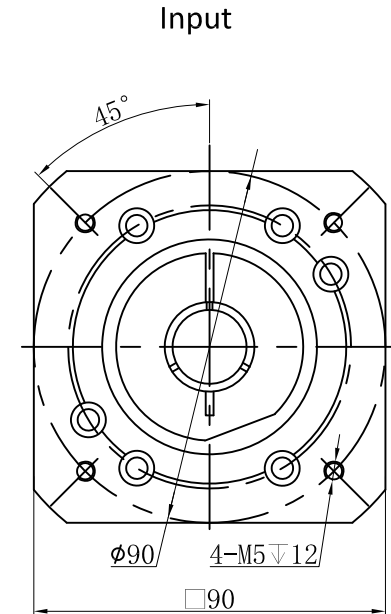
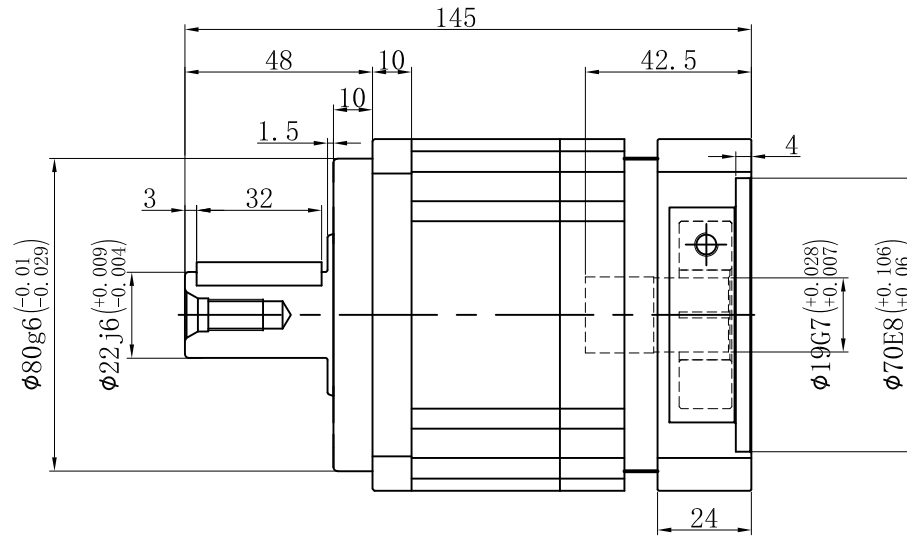
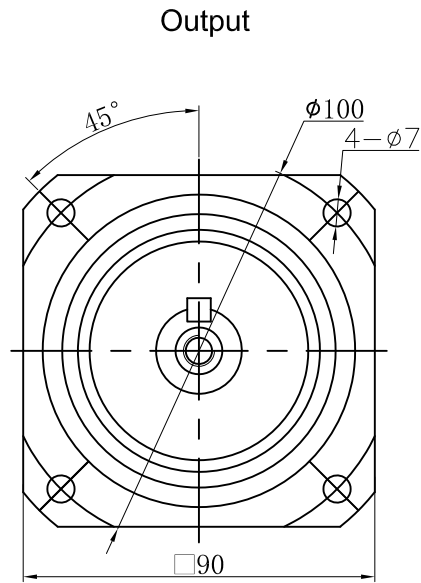

Transmission ratio	(<u> A</u>):1	Mass moments of inertia	(<u> B</u>)Kg.cm ²
Rated output torque	(<u> C</u>)Nm	Max.output torque	(<u> D</u>)Nm
Rated input speed	4000rpm	Max input speed	8000rpm
Max.radial force	3250N	Max.axial force	1625N
Efficiency	≥ 97%	Operating temperature	-20°~+90°
Mounting position	Any	Lubrication method	Synthetic grease
Weight ±3%	3.6Kg	Service life	20000h
Standard backlash	≤ 5 arcmin	Protection class	IP65
Motor power		Noise level	60dB
Motor dimensions			

	6	0.45	148	266.4	Sign/Date					
	5	0.47	160	280			10	0.44	102	183.6
	4	0.48	140	252			8	0.44	123	221.4
	3	0.61	130	234			7	0.45	140	252
Ratio	A	B	C	D		Ratio	A	B	C	D

Note					Precision Planetary Reducer	TB090	
	Mark	No.	Sign	Date		TB090-L1	
	DRAW					Shaft Type	Precision
	CHEC						
	APPR						
	RULE						

Above specifications are for standard reducer and may be subject to change without notice.